

# **Rechargeable Li-ion Battery**

## **FB-L-5.12-EU-Pro**

### **Operation Manual**

Information Version: 1.0  
5PMPA08-20052



# Legal Information

**Copyright©2025 Pylon Technologies Co., Ltd. All rights reserved.**

Any reproduction or distribution of this manual or any part of this manual, or any uploading of this manual to a third party website, in any form by any means, without the prior written consent of Pylon Technologies Co., Ltd., is prohibited.

## **Disclaimer**

The manual contains instructions for the use of the product. All the pictures and charts in this manual are for description and explanation only. Pylon Technologies Co., Ltd. reserves the right to change the information in the manual which is subject to change without further notice.

Please read this manual carefully before using the product and keep this manual for further reference. Failure to use the product in accordance with the manual may result in serious injuries, property damages and may void the warranty, for which Pylon Technologies Co., Ltd. shall not be liable.

Pylon Technologies Co., Ltd. makes no representations or warranties express or implied, with respect to all the information in this manual.

In the event of any conflicts between this manual and the applicable law, the latter prevails.





The final interpretation of this manual belongs to Pylon Technologies Co., Ltd.

# About this Manual

## Purpose

This manual describes the Pylontech Fidus battery FB-L-5.12-EU and FB-L-5.12-EU-Pro in terms of their overview, installation, commissioning, etc. Please read this manual before installing the battery and follow the instructions carefully during installation. In case of any confusion, please contact Pylontech immediately for advice and clarification (Contact information can be found on the back cover of the manual).

## Explanation of Symbols

Symbol	Description
	<b>Danger:</b> Indicates a hazard with a high level of risk which, if not avoided, will result in death or serious injury.
	<b>Warning:</b> Indicates a hazard with a medium level of risk which, if not avoided, could result in death or serious injury.
	<b>Caution:</b> Indicates a hazard with a low level of risk which, if not avoided, could result in minor or moderate injury.
	<b>Notice:</b> Indicates a potentially hazardous situation which, if not avoided, could result in equipment damage, data loss, performance deterioration, or unanticipated results.  NOTICE is used to address practices not related to personal injury.











# Contents

<b>Legal Information</b> .....	<b>I</b>
<b>About this Manual</b> .....	<b>II</b>
Purpose .....	II
Explanation of Symbols.....	II
<b>Contents</b> .....	<b>III</b>
<b>1 Safety</b> .....	<b>1</b>
1.1 Symbols.....	1
1.2 Personal Requirements .....	2
1.3 General Safety .....	2
1.4 Safety Instructions Before Connecting the Battery.....	4
1.5 Safety Instructions in Using the Battery.....	4
<b>2 System Introduction</b> .....	<b>5</b>
2.1 Features.....	5
2.2 Specifications .....	6
2.3 Battery Interface.....	7
2.4 Indicator Description .....	10
2.5 Heating Function.....	14
<b>3 Safe Handling of Lithium Batteries</b> .....	<b>16</b>
3.1 Schematic Diagram of Solution .....	16
3.2 Label.....	16
<b>4 Installation</b> .....	<b>17</b>
4.1 Checking Before the Installation.....	17
4.2 Preparing Tools and Instruments.....	17
4.3 Selecting the Installation Sites .....	18
4.4 Installation Direction.....	19
4.5 Installing the Batteries.....	21
4.5.1 Mounting the Battery on the Wall .....	21
4.5.2 Installing the Battery into the Cabinet or Rack.....	25
4.5.3 Installing the Batteries by Simple Brackets.....	26

<b>5</b>	<b>Cable Connection.....</b>	<b>28</b>
5.1	Checking Cables.....	28
5.2	Connecting the Grounding Cable.....	28
5.3	Single-string Cable Connection .....	30
5.4	Multi-string Cable Connection .....	32
5.5	Suitable Disconnection Device.....	33
<b>6</b>	<b>Commissioning.....</b>	<b>34</b>
6.1	System Turning On.....	34
6.2	System Turning Off.....	35
<b>7</b>	<b>Troubleshooting .....</b>	<b>36</b>
<b>8</b>	<b>Emergency Situations.....</b>	<b>40</b>
<b>9</b>	<b>Remarks .....</b>	<b>41</b>
9.1	Recycle and Disposal.....	41
9.2	Storage, Maintenance and Expansion .....	41

# 1 Safety

## 1.1 Symbols

Icon	Meaning	Icon	Meaning
	Read the manual before installing and operating the product.		Do not connect the positive and negative reversely.
	General warning label indicating potential hazards.		Keep away from flame or ignition sources.
	Warning: electric shock.		Keep away from children.
	Warning: flammable materials.		Label for Waste Electrical and Electronic Equipment (WEEE) Directive (2012/19/EU).
	Warning: Do not touch the enclosure of the operating product.		The system meets the requirements of the applicable EU directives.
	The IEC certificate label for Safety by TÜV Rheinland.		

## 1.2 Personal Requirements

Qualified personnel must have the following skills:

- Training in the installation and commissioning of the electrical system, as well as the dealing with hazards.
- Knowledge of the manual and other related documents.
- Knowledge of the local regulations and directives.

## 1.3 General Safety

### Declaration

This system is only operated by authorized personnel. Read all safety instructions carefully prior to any work and follow these instructions at all times when working with the system.

Incorrect operation or work may cause:

- Injury or death to the operator or a third party.
- Damage to the system hardware and other properties belonging to the operator or a third party.

### General Requirements

#### DANGER

**Danger:** Batteries deliver electric power, resulting in burns or a fire hazard when short circuit or incorrect installment occurs.

#### DANGER

**Danger:** Lethal voltages are present in the battery terminals and cables. Severe injuries or death may occur if you touch the cables and terminals.

#### WARNING

**Warning:** DO NOT open or deform the battery module, otherwise the product will be out of warranty scope.

#### WARNING

**Warning:** Whenever operating the battery system, wear suitable personal protective equipment (PPE) such as rubber gloves, rubber boots and goggles.

 **WARNING**

**Warning:** For battery installation, the installer shall refer to NFPA70 or similar local installation standard for operation.

 **WARNING**

**Warning:** Pulling out the connectors while the system is working could lead to battery system damage or personal injury. Do not pull out the connectors while system is in operation.

 **CAUTION**

**Caution:** Improper settings or maintenance can permanently damage the battery.

 **CAUTION**

**Caution:** Battery needs to be recharged within 12 hours, after fully discharged.

 **CAUTION**

**Caution:** Risk of electric shock, do not remove cover. There is no user serviceable parts inside, refer servicing to qualified and accredited service technicians

 **WARNING**

**Warning:** Operations below must be accomplished by licensed technician or Pylontech authorized person.

## 1.4 Safety Instructions Before Connecting the Battery

### CAUTION

#### Caution:

- After unpacking, please check product and packing list first, if the product is damaged or lack of parts, please contact the local retailer.
- Before installation, ensure to cut off the grid power and ensure that the battery is in the switched-off mode.
- Wiring must be correct, do not mistake the positive and negative cables, and ensure no short circuit with the external device.
- DO NOT connect the battery with AC power directly.
- The embedded BMS in the battery is designed for 51.2 VDC. DO NOT connect battery in series.
- Battery system must be well grounded and the resistance must be less than 100 mΩ.
- Please ensure the electrical parameters of battery system are compatible to related equipment.
- Keep the battery away from water and fire.

## 1.5 Safety Instructions in Using the Battery

### CAUTION

#### Caution:

- If the battery is stored for long time, it is required to be recharged every six months, and the SOC should not be less than 50%.
- Battery needs to be recharged within 12 hours after being fully discharged.
- If the battery system needs to be moved or repaired, the power must be cut off and the battery is completely shut down in advance.
- DO NOT connect the battery with other different type of battery.
- DO NOT let the batteries work with faulty or incompatible inverter.
- DO NOT disassemble the battery (QC tab removed or damaged).
- In case of fire, only dry powder fire extinguisher can be used. DO NOT use liquid fire extinguishers.
- DO NOT open, repair or disassemble the battery unless by staff from Pylontech or authorized by Pylontech. We do not undertake any consequences or related responsibility due to violation of safety operation or violation of design, production and equipment safety standards.

## 2 System Introduction

### 2.1 Features

Pylontech Fidus Battery EU is a new low-voltage battery with high protection level launched by Pylontech in 2025. It is available in two versions, namely the standard version and the low-temperature heating version, and is suitable for application scenarios across all regions in Europe.

The following are the features of Fidus Battery EU.

- Strong environmental adaptability with IP65 protection design, applied in outdoor or high humidity scenarios,
- Wall mounting design, compatible with plug-in box and self-stacking, achieving a variety of installation methods.
- Enabling 95% depth of discharge, available for latest low-voltage communication protocol of Pylontech.
- Up to 20 batteries in parallel can be supported in single string, up to 6 strings of batteries can be expanded to parallel use.
- External Wi-Fi stick can be hung to realize the whole group of battery information networking to the cloud, using Pylontech APP or Pylontech cloud to view the battery data.
- Supporting 1 C continuous, 1.2 C overload 2 minutes and 2 C overload 15 seconds.
- Automatically managing charging and discharging state and balancing voltage of each cell.
- Supporting CAN/485 two forms of communication; Upgrading battery module through CAN or 485 communication; Support remote upgrade.
- FB-L-5.12-EU-Pro supports low-temperature heating function.

## 2.2 Specifications

Specifications	FB-L-5.12-EU	FB-L-5.12-EU-Pro
Nominal Voltage (VDC)	51.2	
Nominal Capacity (Wh)	5120	
Usable Capacity (Wh)	4864	
Depth of Discharge (%)	95	
Dimensions (mm)	600(W) × 361(D) × 168(H)	
Weight (Kg)	44.5±0.5	45.8±0.5
Discharge Voltage (VDC)	44.8~56.8	42.5~56.8
Charge Voltage (VDC)	56 ~ 56.8	
Maximum Continuous Charge/Discharge Current (A) *	100/100	
Peak Charge/Discharge Current (A)	103 ~ 120 @2 minutes 121 ~ 200 @15 seconds	
Communication	RS485, CAN	
Configuration (maximum quantity in one battery group)	20	
Configuration (maximum strings)	6	
Working Temperature(°C)**	-10 ~ 55	-20~55
Storage Temperature (°C)	-20 ~ 60	
Short Current/Duration Time (A/1ms)	< 1,000	
Cooling Type	Natural	
Protective Class	I	
IP Rating of Enclosure	IP65	
Anti-corrosion	C5-M	
Humidity(% , RH, No Condensation)	5 ~ 95	
Altitude(m)	≤ 4000	
Certifications	IEC62619, IEC63056, VDE-AR-E 2510-50, IEC62477-1, EMC/CE	
Environmental protection	RoHS, Reach, WEEE,	
Transportation	UN38.3	
Design Life (year) (25°C /77°F)	10	
Cycle Life (25°C /77°F) **	8000	
Interaction	LED,Bluetooth and WI-FI(Optional)	

\*: Support Maximum 100A charge/discharge current, the recommended current will change dynamically according to the real-time status of the battery during operation;

\*\* : In low and high temperature section, BMS will reduce the recommended current and need to

be used with reduced power;  
 \*\*: 25°C/0.5C, for details, please seek technical support from PylonTech.

### 2.3 Battery Interface

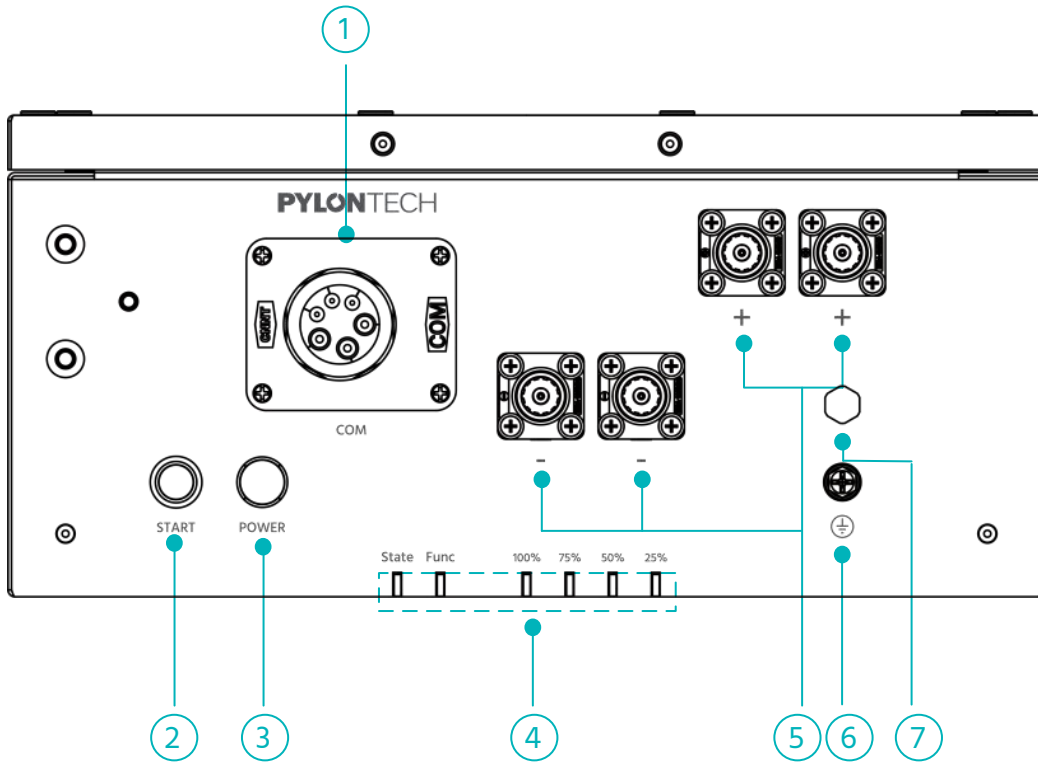

No.	Name	Description																		
1	Communication Terminals	<p>Before connecting the communication terminals, loosen the 4 screws on the cover as follows, then you will see the communication terminals.</p> <ul style="list-style-type: none"> <li>RS485: 9600 or 115200 bps.</li> <li>CAN: 500 Kbps.</li> </ul> <table border="1"> <thead> <tr> <th>PIN</th> <th>CAN/RS485</th> </tr> </thead> <tbody> <tr> <td>Pin1</td> <td></td> </tr> <tr> <td>Pin2</td> <td>/</td> </tr> <tr> <td>Pin3</td> <td></td> </tr> <tr> <td>Pin4</td> <td>CAN-H</td> </tr> <tr> <td>Pin5</td> <td>CAN-L</td> </tr> <tr> <td>Pin6</td> <td>CAN-GND</td> </tr> <tr> <td>Pin7</td> <td>485A</td> </tr> <tr> <td>Pin8</td> <td>485B</td> </tr> </tbody> </table>	PIN	CAN/RS485	Pin1		Pin2	/	Pin3		Pin4	CAN-H	Pin5	CAN-L	Pin6	CAN-GND	Pin7	485A	Pin8	485B
PIN	CAN/RS485																			
Pin1																				
Pin2	/																			
Pin3																				
Pin4	CAN-H																			
Pin5	CAN-L																			
Pin6	CAN-GND																			
Pin7	485A																			
Pin8	485B																			

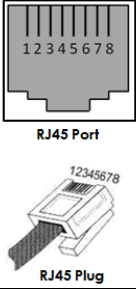
No.	Name	Description
		<ul style="list-style-type: none"> <li>Link port 0/Link port 1: For communication between multiple parallel batteries.</li> </ul> 
2	Start button	<p>Turn On/Off the System</p> <ul style="list-style-type: none"> <li>After powering on, short press the START button to start the device.</li> <li>Hold the START button for 5 seconds to shut down the device.</li> </ul> <p><b>NOTE:</b> For the operation of “Turn off” or “Functional reuse” (baud rate switching), please pay attention to the duration of the long pressing button.</p>
3	Power button	<ul style="list-style-type: none"> <li>Press the POWER button to turn on the system.</li> <li>Press the POWER button again to turn off the system.</li> </ul> <p><b>NOTE:</b> Please keep the battery powered off during storage or transportation.</p>
4	LED status indicators	It is important to check the detailed alarm/protection definitions according to the following table for trouble-shooting and maintenance service. For details, see the table below.
5	Power terminal(s)	There are two pair of terminals with same function, one is connected to equipment, the other is connected in parallel to other battery modules for capacity expansion.
6	Grounding point	To connect the grounding cable.
7	Vent Valve	To balance the air pressure inside and outside the battery

## Communication Terminals

Before connecting the communication terminals, loosen the 4 screws on the cover as follows, then you will see the communication terminals.

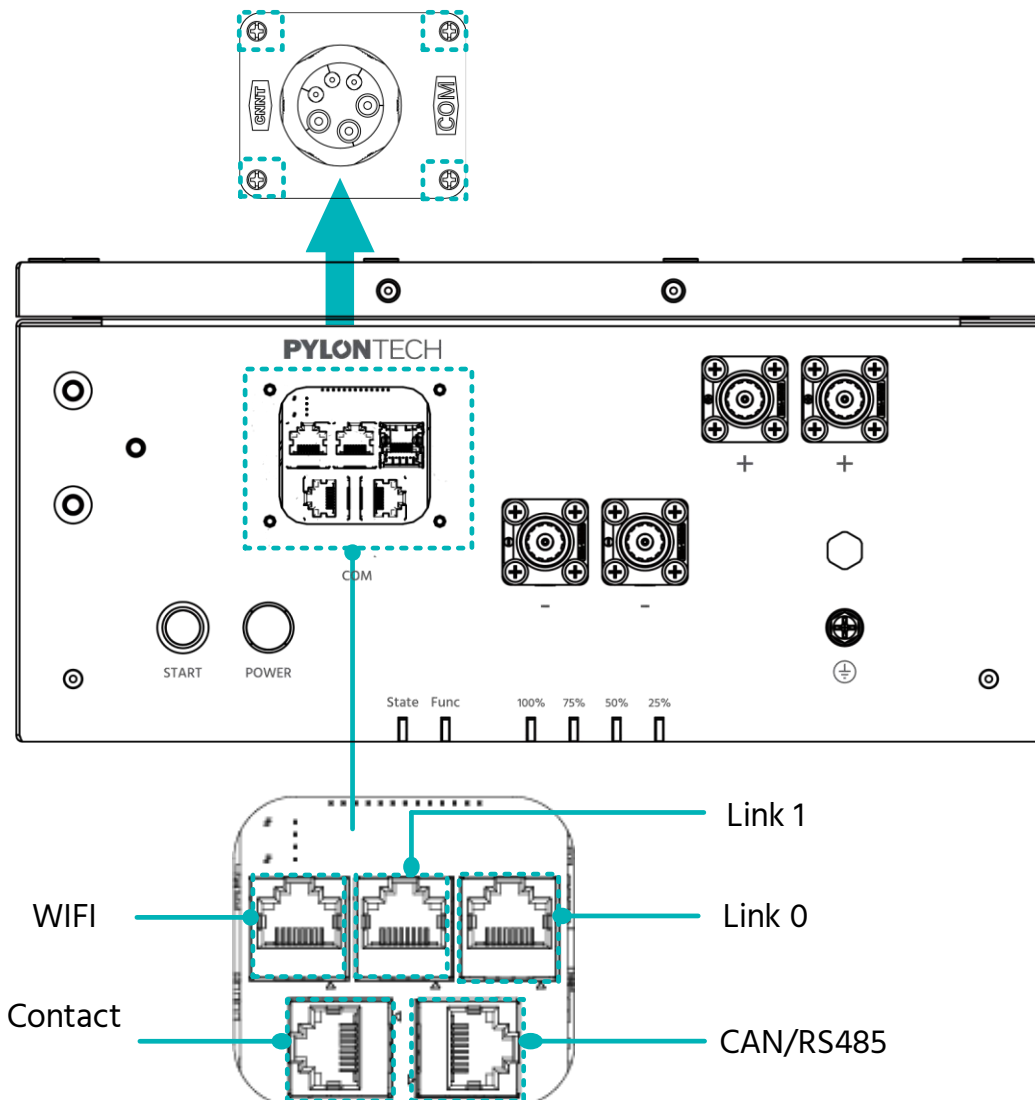

- **WIFI:** Used for connecting to Pylontech data acquisition sticks, enabling the upload of battery data to the cloud for real-time monitoring, upgrade and maintenance.
- **LINK0/LINK1:** Used for parallel connection between batteries; see *Section 4 Installation* for more details.
- **Contact:** Reserved.
- **CAN/485:** Used for connecting to the PCS communication port (the communication mode with PCS needs to be confirmed).

## 2.4 Indicator Description

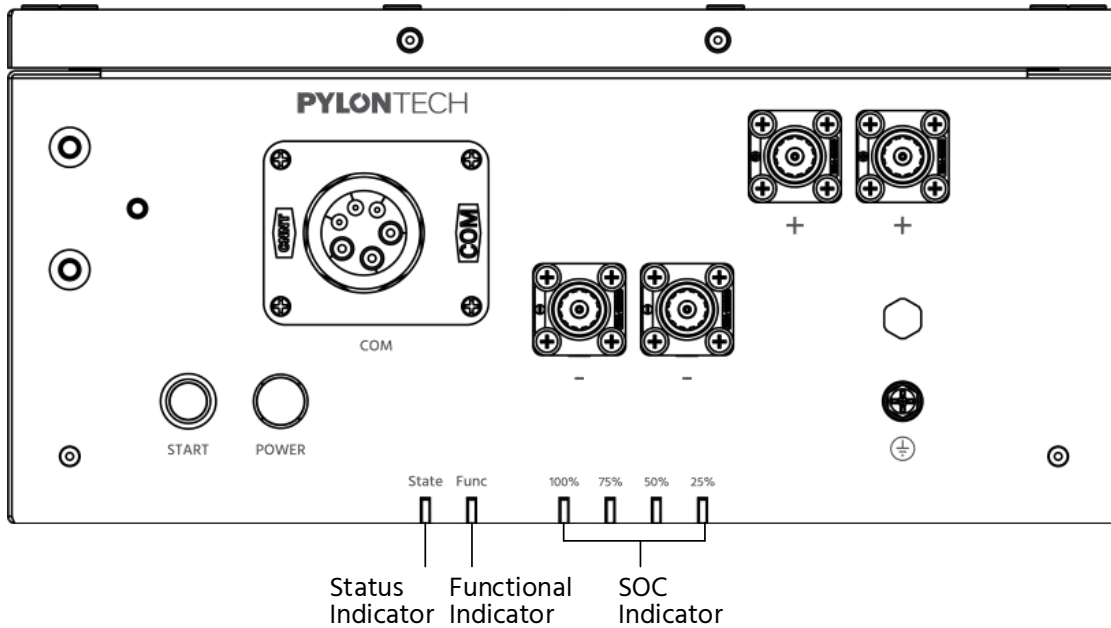

- View/Enable/Disable Heating Film

After turning on the device, short press the START button once, and the Func indicator will turn green.

- Func Indicator Solid Green: Heating function activated
- Func Indicator Flash Green: Heating function deactivated

If you want to enable/disable heating film, long press the START button for 2 seconds.

- View/Switch Baud Rate

After turning on the device, short press the START button twice, and the Func indicator will turn orange. (The Func light will turn green the first time you press the START button).





- Func Indicator Solid Orange: baud rate of 9600.
- Func Indicator Flash Orange: baud rate of 115200.
- 

**NOTE:**





- For heating model batteries, the Heating Film View/Enable/Disable function is supported.
- For non-heating model batteries, the Baud Rate View/Switch function is supported.

If you want to switch the baud rate, long press the START button for 2 seconds.



**If no operation is performed for 10 seconds, the function operation mode will exit.**

 Light Off	 Light Steady On	 Fast Flash 1s On 1s Off	 Slow Flash 0.5s on 2s Off	*Slow flashing occurs only when the device is in standby mode.
*The colors above are for illustration only. See the image below for the actual colors.				

### Indicator Description Table

Indicator		Status	Meaning
State Indicator	<b>State</b> 	Fast Flash Red	Device exception. For details, refer to <b><i>Alarm Indicator Table</i></b> .
	<b>State</b> 	Solid Red	Serious exception. MOS fails. Fuse is blown.
Function Indicator	<b>Func</b> 	Solid Green	The heating film is heating.
	<b>Func</b> 	Solid Orange	Heating film fails.

### Normal Operation SOC Indicator Description Table

Indicator		Status	Meaning
SOC Indicator	<b>100%</b> <b>75%</b> <b>50%</b> <b>25%</b> 	One Indicator Solid Green	Device is charging. *The left picture shows an example of a scenario where the power level is between 51%~75%. For example, if the 50% indicator is solid green, it means that the device is charging and the power level is between 26%~50%. The same applies to other situations.
	<b>100%</b> <b>75%</b> <b>50%</b> <b>25%</b> 	One Indicator Slow Flash Green	Device is on standby. *The left picture shows an example of a scenario where the power level is between 51%~75%. For example, if the 50% indicator is slow flash green, it means that the device is on standby and the power level is between 26%~50%. The same applies to other situations.

	<p>100% 75% 50% 25%</p>	<p>One/more Indicator(s) Flash Green</p>	<p>Device is discharging. *The left picture shows an example of a scenario where the battery level is between 51%~75%. If the 25% and 50% indicators are flash green, it means that the device is discharging and the power is between 26%~50%. The same applies to other combinations.</p>
	<p>100% 75% 50% 25%</p>	<p>100% Indicator Solid Green Other Indicators Flash Green</p>	<p>Device is float charging.</p>

### Alarm Indicator Table

**CAUTION**

**Caution:** In this case, the power indicator does not represent the power level.

	State Indicator	SOC Indicator	Status	Meaning
Status Indicator	<p><b>State</b></p> <p>Fast Flash Red *Fast flash red indicates device exception. The specific abnormality needs to be determined with SOC indicators.</p>	<p>100% 75% 50% 25%</p>	<p>100% Indicator Solid Green</p>	<p>Protection Mode. Charging MOS OFF.</p> <ul style="list-style-type: none"> <li>- Charging overcurrent</li> <li>- Battery overvoltage.</li> <li>- Input overvoltage.</li> <li>- Etc.</li> </ul>
		<p>100% 75% 50% 25%</p>	<p>75% Indicator Solid Green</p>	<p>Protection Mode. Discharging MOS OFF.</p> <ul style="list-style-type: none"> <li>- Overcurrent discharge.</li> <li>- Positive and negative pole</li> </ul>

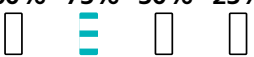
				<p>short circuit.</p> <ul style="list-style-type: none"> <li>– Positive and negative pole reverse connection.</li> <li>– Battery undervoltage.</li> </ul>
		<p>100% 75% 50% 25%</p> 	<p>100% &amp; 75% Indicators Solid Green</p>	<p>Protection Mode. Charging &amp; Discharging MOS are both OFF.</p>
		<p>100% 75% 50% 25%</p> 	<p>Any Indicator Slow Flash Green. *The left picture is for illustration only.</p>	<p>Internal communication failure. Address allocation error.</p>

## 2.5 Heating Function

The FB-L-5.12-EU-Pro battery is equipped with a heating function. The relevant logic and precautions for using are as follows:

### System Default Settings

The heating function of the heating model battery is enabled by default, and heating will automatically start when the heating trigger conditions are met.

The battery's default heating activation temperature is triggered when the minimum battery temperature ( $T_{\min}$ )  $\leq 0^{\circ}\text{C}$ , and the default heating shutdown temperature is triggered when

$T_{\min} \geq 5^{\circ}\text{C}$ .

The default heating time is 24 hours a day.

### APP Settings for Heating Function Parameters

The heating enable can be set. If the heating enable is set to off, the system will operate as a non-heating model battery.

The heating activation temperature and heating shutdown temperature can be customized according to customer needs. Once set successfully, the system will operate according to the set parameters.

A maximum of 3 heating time periods can be set. Once set successfully, heating will start/stop according to the set parameters. If the heating shutdown conditions are met within the set time period, heating can stop in advance.

### Logic

The priority order of energy sources for system heating is: photovoltaic, battery, mains electricity.

- If photovoltaic energy is sufficient, it will be used for battery heating.
- If photovoltaic energy is insufficient and the battery SOC  $\geq 30\%$ , battery energy will be used for heating.
- If photovoltaic energy is insufficient and the battery SOC  $< 30\%$ , the battery is not allowed to discharge for self-heating, and it is necessary to request PCS inverter output for heating (Note: Grid energy will be used in this process).

 **CAUTION**

**Caution:**

- It is necessary to ensure that all batteries in the parallel system are heating model batteries, i.e., all are FB-L-5.12-Pro. When mixed with FB-L-5.12 batteries, the heating function of the heating models will not take effect.
- If you do not want to use this heating function, you can disable the heating enable through the battery button or in the APP.
- The minimum allowable operating temperature of the battery is -20°C. If the battery temperature is below -20°C, the battery will not be allowed to be used, including the heating function.
- It takes only 2 hours to heat the battery from -20°C to a minimum temperature of  $\geq 5^{\circ}\text{C}$ . However, if the battery power is insufficient and the heating power output by the PCS is insufficient, the heating effect will be affected.
- When using the battery in a normal temperature environment, if the battery reports a heating function fault, the heating function can be disabled temporarily, and the battery can be used as a non-heating model.

# 3 Safe Handling of Lithium Batteries

## 3.1 Schematic Diagram of Solution

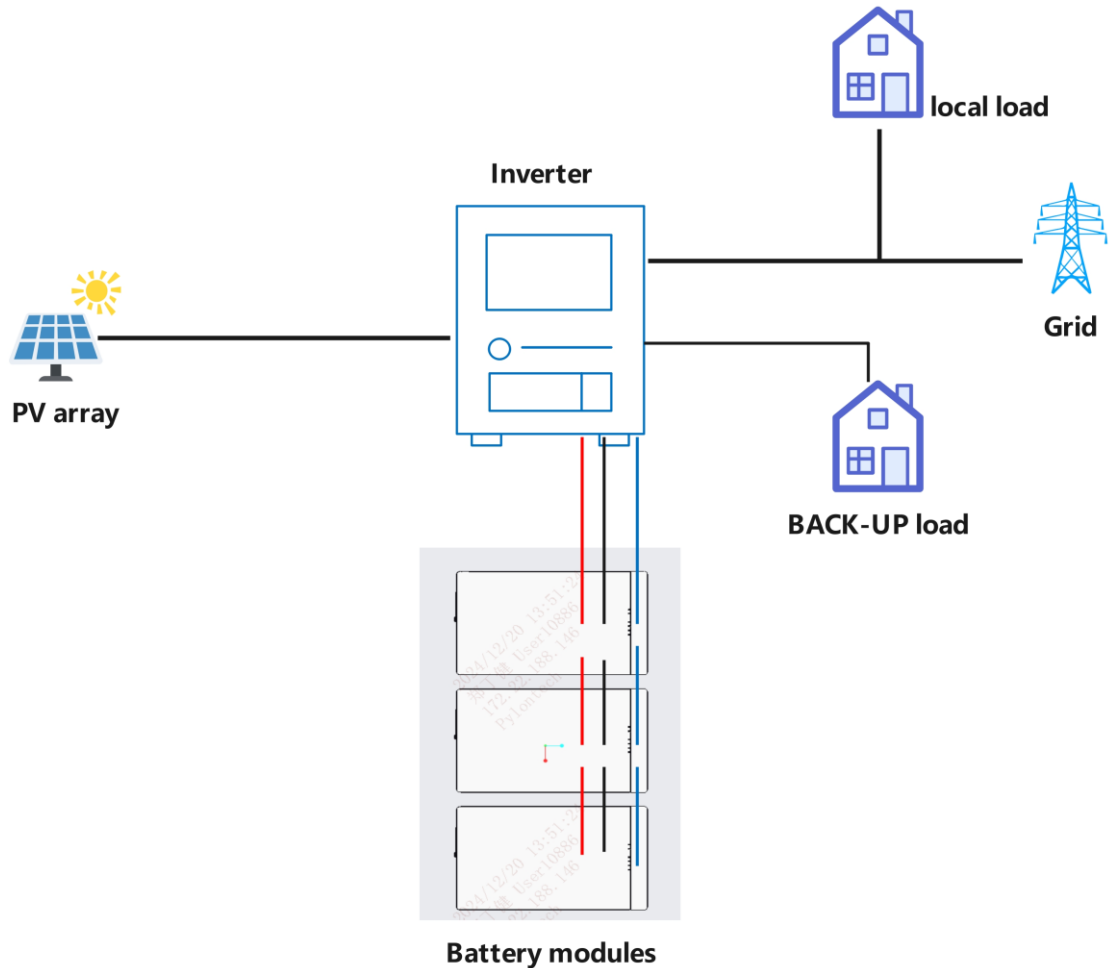

## 3.2 Label

		<b>Rechargeable Li-ion Battery</b>	
<b>Registration</b>	<b>Battery Designation:</b> IFpP17/156/392/1165/M/0+50/95 <b>Battery Category:</b> Industrial Battery <b>Model:</b> FB-L-512-EU <b>Part Number:</b> 11FB5000ZB-20000 <b>Rated Energy/Capacity:</b> 5.12KWh/100Ah <b>Nominal Voltage:</b> 51.2V <b>Charge Voltage:</b> 56~56.8V <b>Maximum Charging/Discharging Current:</b> 100A/100A <b>Short Current/Duration:</b> ..... <b>SN:</b> Y250717C80000001	<b>Operating Temperature:</b> -10~55°C <b>Protection Class:</b> I <b>IP Rating:</b> IP65 <b>Weight:</b> 42kg <b>Chemistry:</b> LiFePO4/LiPF6/Graphite <b>Critical Raw Materials:</b> LiFePO4/LiPF6/Graphite <b>Hazardous Substances:</b> / <b>Usable Extinguishing Agent:</b> A/B/C/F	<b>Date of Production:</b> 2025.09 
<b>Manual</b>		<b>DANGER</b> DANGER LOW DC VOLTAGE INSIDE DANGER TENSION BASSE A L'INTERIEUR DANGER ARC FLASH & SHOCK HAZARD DANGER D'ARC ELECTRIQUE ET DE RISQUE D'ELECTROCUTION	
		<ul style="list-style-type: none"> <li>Do not disconnect, disassemble or repair by yourself. Ne pas débrancher, démonter ou réparer soi-même.</li> <li>Do not drop, deform, impact, cut or spear with a sharp object. Ne pas échapper, déformer, frapper, couper ou transpercer avec un objet pointu.</li> <li>Do not place near open flame or incinerate. Ne pas placer près des flammes nues ou incinérer.</li> <li>Do not sit or put heavy things on battery. Ne pas s'asseoir ou mettre des objets lourds sur la batterie.</li> <li>Keep away from moisture or liquid. Tenir loin de l'humidité ou de tout liquide.</li> <li>Keep out of reach of children, animals or insects. Garder hors de la portée des enfants, des animaux ou des insectes.</li> <li>Contact your supplier within 24 hours if anything failure happens. Contactez votre fournisseur dans les 24 heures en cas de panne.</li> </ul>	

Pylon Technologies Co., Ltd | www.pylontech.com.cn | Address: No.300, Miaojiao Road, Kangqiao Town, Pudong New Area, Shanghai 201315, China  
The place of manufacture: 215400 No.7, Xiyuan 3rd Road, Yuheng Economic Development Zone, Yangzhou, Jiangsu Province, China

## 4 Installation

### CAUTION

**Caution:** According to local electric safety and installation policy, a suitable disconnection device between battery system and inverter could be installed.

All the installation and operation must follow local electric standards.







### 4.1 Checking Before the Installation

#### Checking the Outer Packing and Deliverables

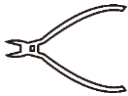
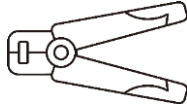
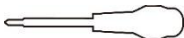
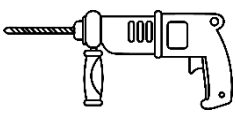
- After receiving the product, check the outer packing for damage, such as holes, cracks, deformation and so on. If any damage is found, contact the local retailer as soon as possible.
- After unpacking the product, check that the deliverables are complete. If any item is missing or damaged, contact the local retailer as soon as possible.

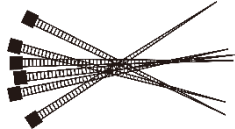
### 4.2 Preparing Tools and Instruments

#### Tools and Instruments

Type	Tools and Instruments		
Installation			
	Wire Cutter	Crimping Plier	Screwdriver
			
	Hammer Drill	Socket Wrench Set	Cable Ties
Personal protective equipment (PPE)			
	Insulated Gloves	Safety Goggles	Safety Shoes
			
Anti-arc Flash Suit			

**NOTE:** Use properly insulated tools to prevent accidental electric shock or short circuits. If insulated tools are not available, cover the entire exposed metal surfaces with available insulated alternatives, except their tips, with electrical tape.

## 4.3 Selecting the Installation Sites

### Working Environment Requirements

#### CAUTION

##### Caution:

If the ambient temperature is out of the operating range, the battery stops working to protect itself. The optimal temperature range for the battery module operation is 15 °C to 40 °C.

Frequent exposures to harsh temperatures may deteriorate the performance and life of the battery.

Ensure that the installation location meets the following conditions:

- Ensure that the battery is not soaked in water.
- The floor is flat. Or if the wall is strong enough to support the battery wall mounting
- There are no flammable or explosive materials.
- The ambient temperature is within the range from 0 °C to 50 °C.
- There is minimal dust and dirt in the area.
- The distance from heat source is more than 2 meters.
- The distance from air outlet of inverter is more than 0.5 meters.
- The installation areas should be protected from direct sunlight.
- There are no mandatory ventilation requirements for the battery module, but please avoid of installation in confined area.
- Do not place heavy objects on top of the battery after installation, and it is recommended to set up isolation in the battery installation area to avoid dropping the battery and hitting people or animals.
- This product supports offshore installation, with the installation location required to be at least 500 meters from the coastline. Within 1 kilometer of the coastline, obstacles must be placed directly in front of the battery (facing the coast) to prevent direct sea breeze on the battery surface; beyond 1 kilometer, no obstacles are needed for installation.

## 4.4 Installation Direction

Recommended:

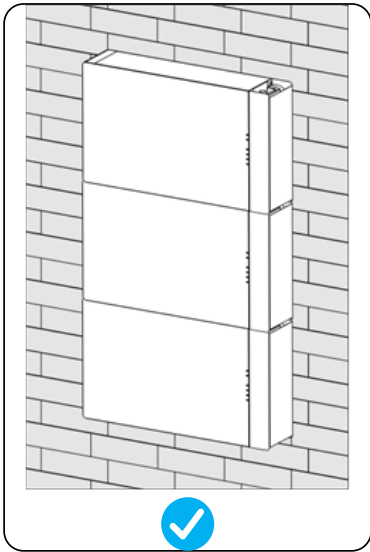

Mounted on the wall.

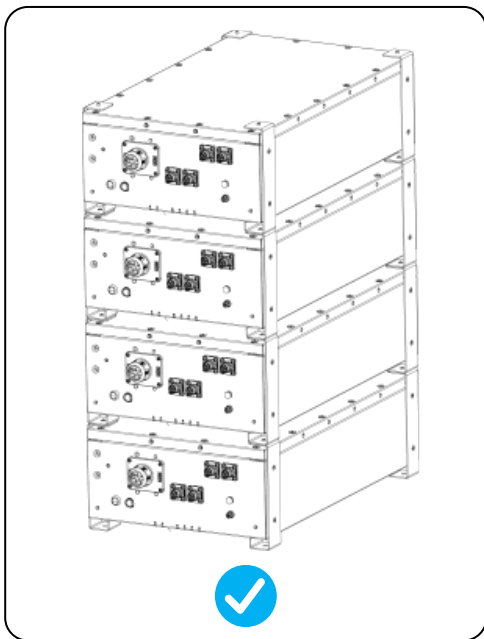

Stacked by simple brackets

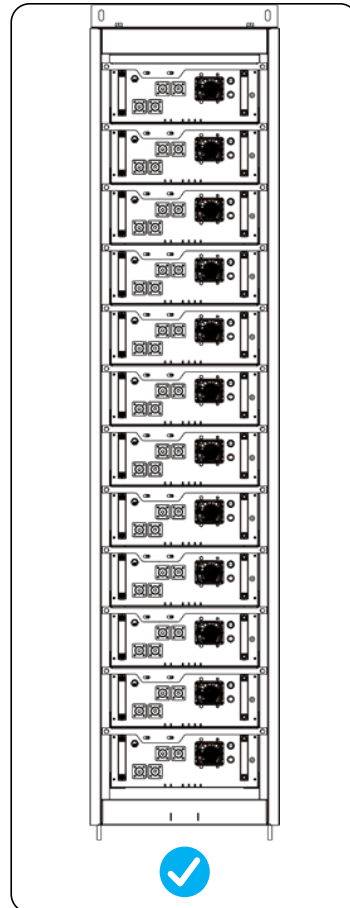

Installed into the cabinet or the rack.

**NOT allowed:**

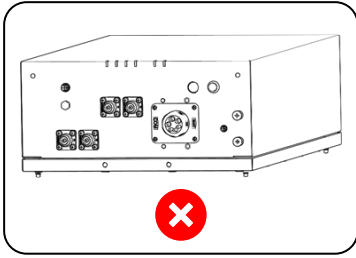

Do **NOT** place the cover plate facing downwards.

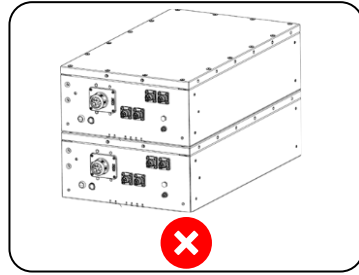

Do **NOT** stack modules together directly.

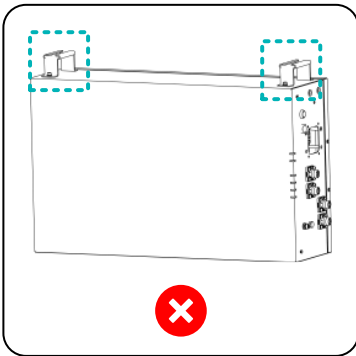

Do **NOT** hang the module by the handles.

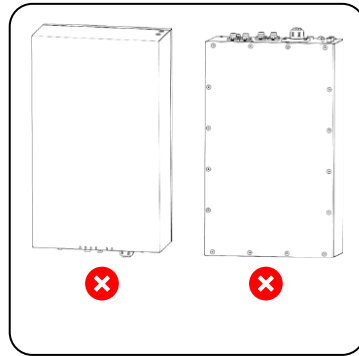

Do **NOT** put the module in the upright position.

## 4.5 Installing the Batteries

There are 3 installation methods for battery modules based on different usage preferences.

### 4.5.1 Mounting the Battery on the Wall

#### Procedure

1. Put the wall bracket on the wall horizontally and mark positions for drilling holes.

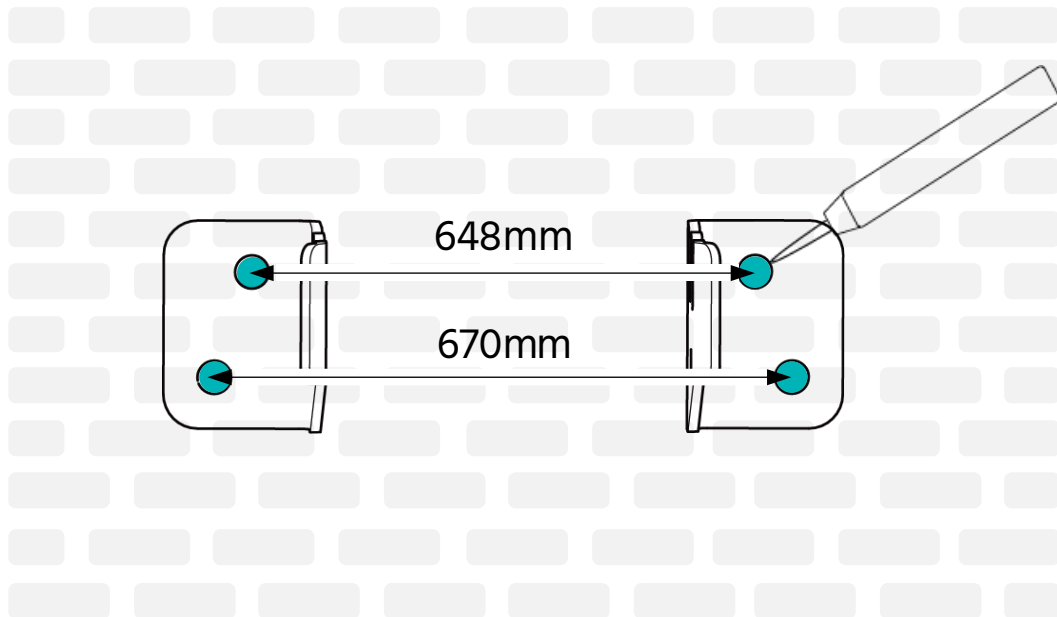

2. Drill holes to a depth of 65 mm using the hammer drill.

The diameter of the drill bit should be 10mm.

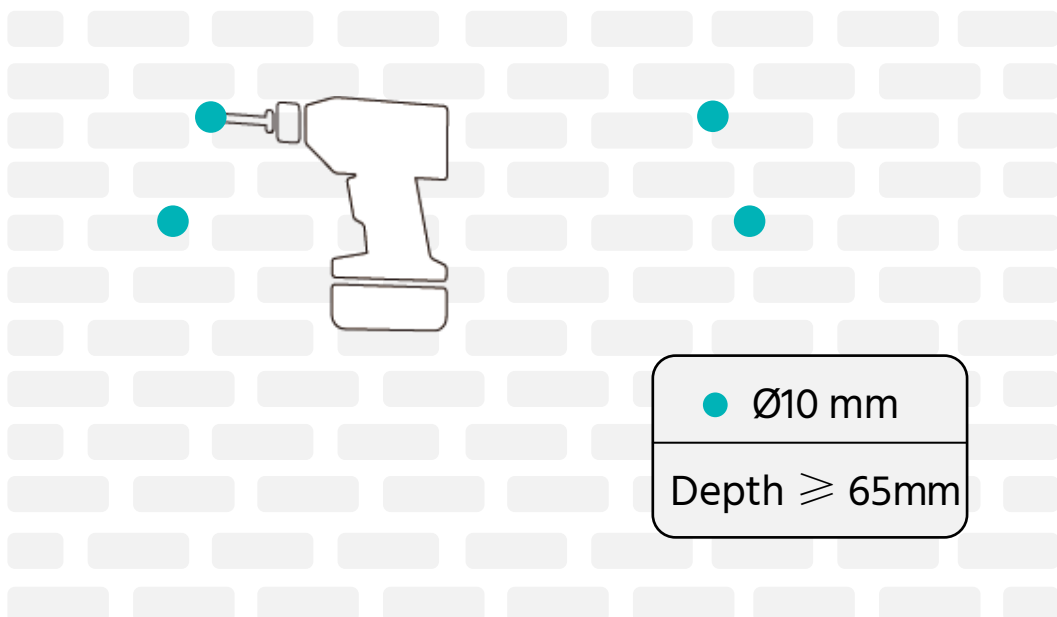

3. Secure the wall bracket using the M6 × 60 expansion bolts (tightening torque: 7 Nm).

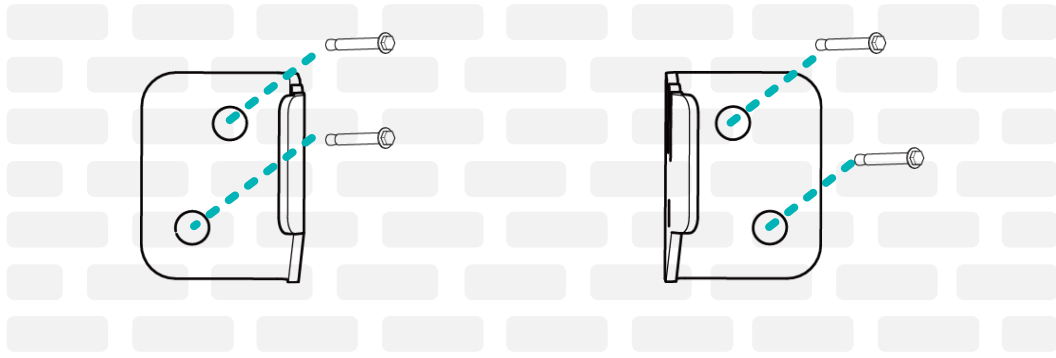

4. Use 4 M6 × 15 screws to install the 2 mount fixings to the both sides of the battery with M6 screws (tightening torque: 5 Nm).

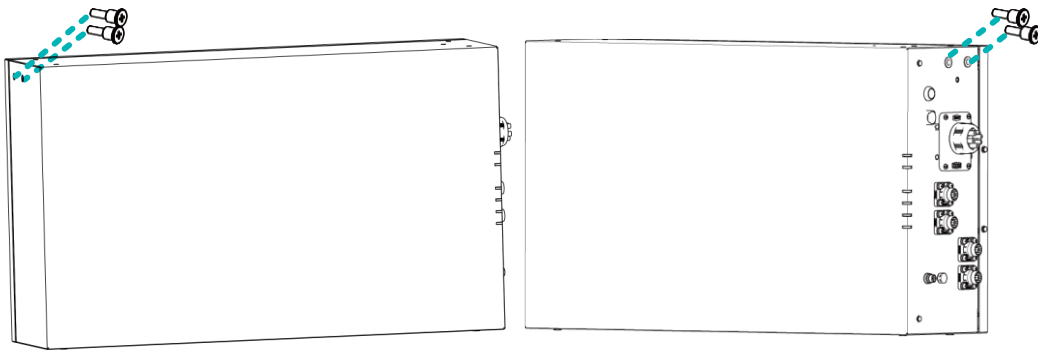

5. Use 4 M5 × 12 screws to install the handles.

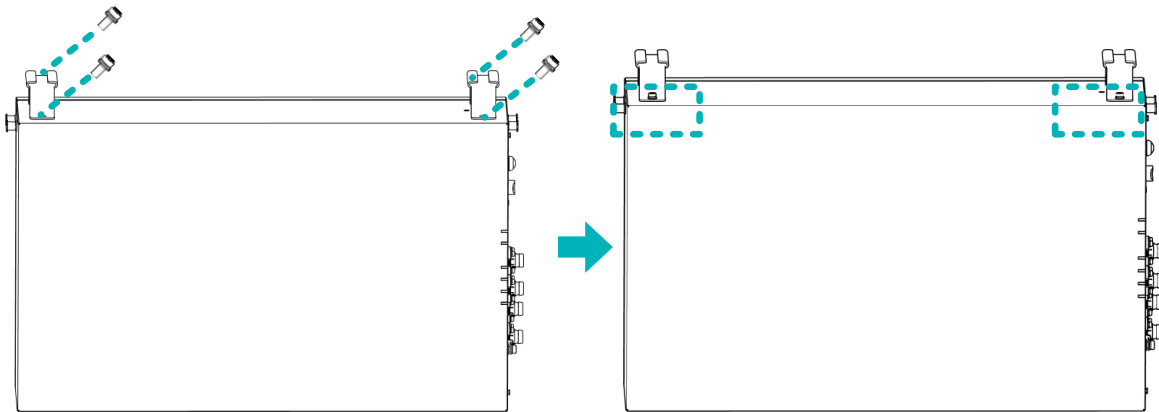

6. Lift the 2 handles on the battery and adjust to keep the mount fixings of the battery align with the wall brackets, and slowly put down the battery to fit it properly on the wall bracket.

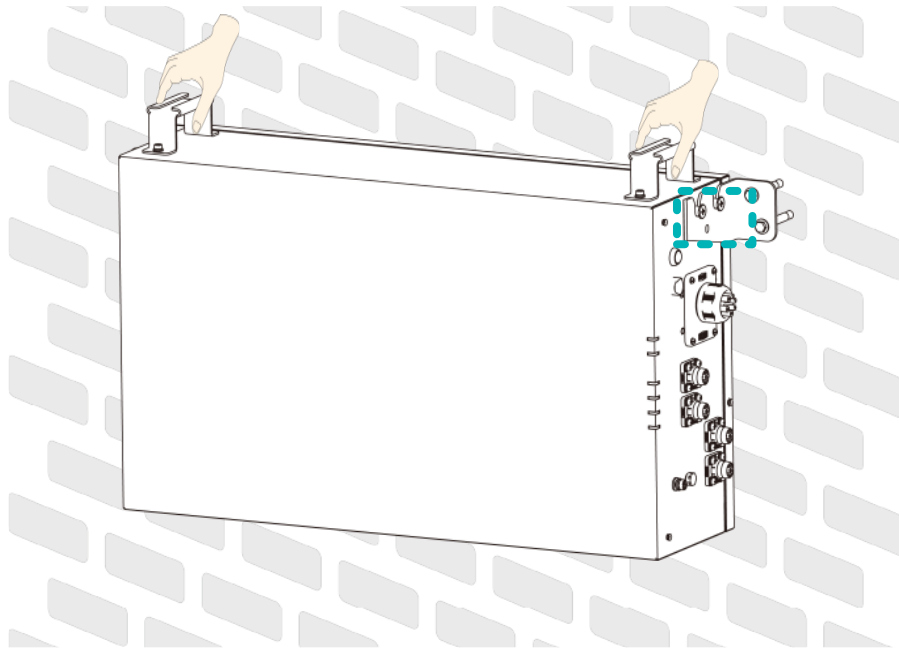

7. Fasten the mount fixings to the wall bracket with M5 × 16 screws (tightening torque: 5 Nm).

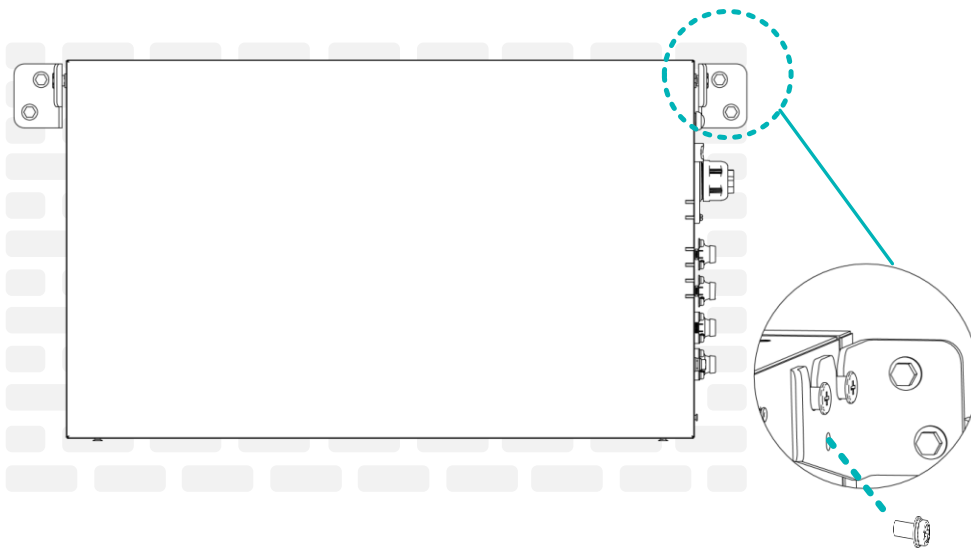

8. (If any) Repeat the step 1 to step 7 above if more than one battery needs to be installed.
9. Connect the cables. (>>>Chapter 5 Cable Connection).
10. Install the decorative cover onto the battery.

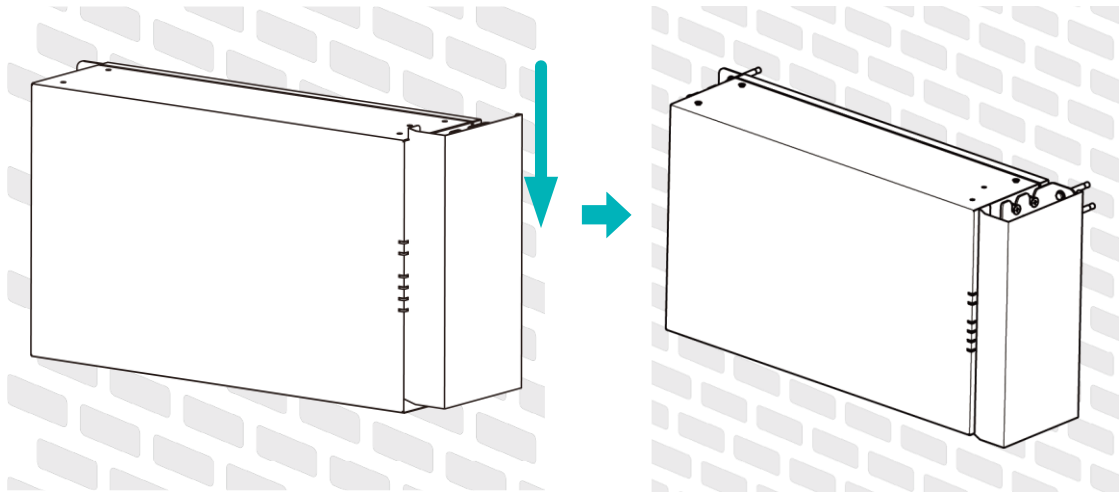
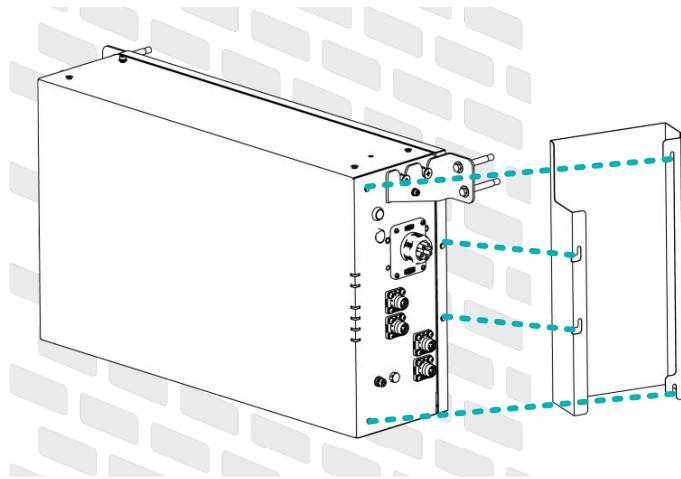

**NOTE:** If more than one battery needs to be mounted, ensure that the distance between the upper wall bracket and lower wall bracket is greater than the height(370 mm) of one battery.

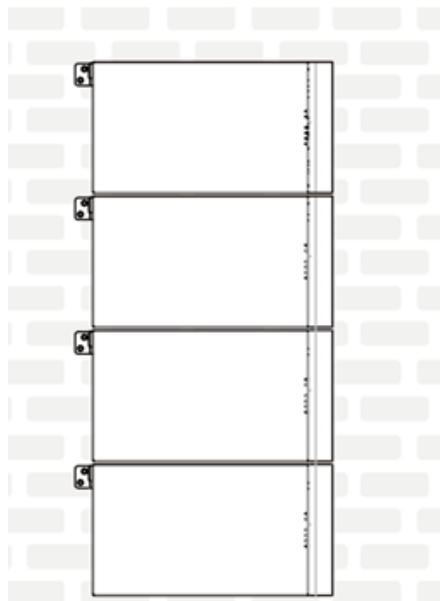

## 4.5.2 Installing the Battery into the Cabinet or Rack

### Procedure

1. Put the battery into the cabinet or the rack.

**NOTE:** Ensure that the cover plate is facing upwards.

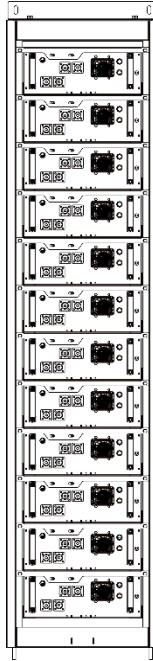

### 4.5.3 Installing the Batteries by Simple Brackets

Up to 4 batteries can be installed by brackets.

#### Procedure

1. Place the device horizontally on the ground as shown below.

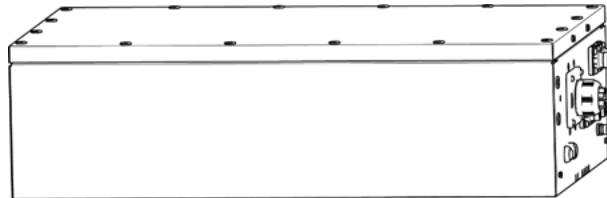

2. Secure the brackets to the battery with 8 M5 × 10 screws (tightening torque: 4 Nm).

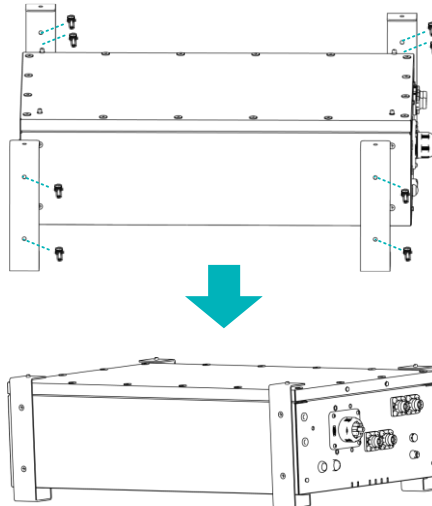

3. Clamp the slots of the upper and lower brackets tightly to ensure no looseness.

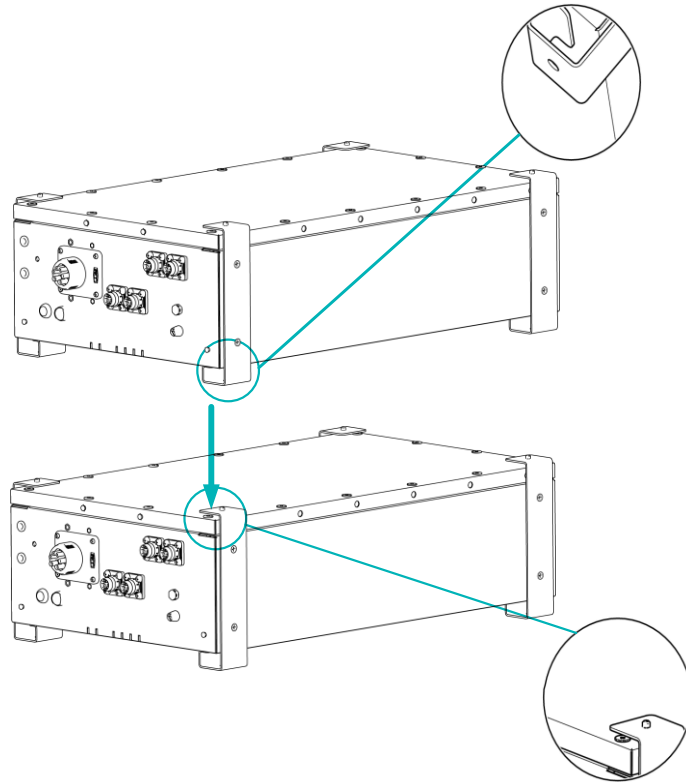

4. Repeat step 1 ~ step 3 above if more than 2 batteries need to be installed.

**NOTE:** Maximum 4 batteries are allowed for stacking in one vertical row due to the load-carrying capability of the simple brackets.

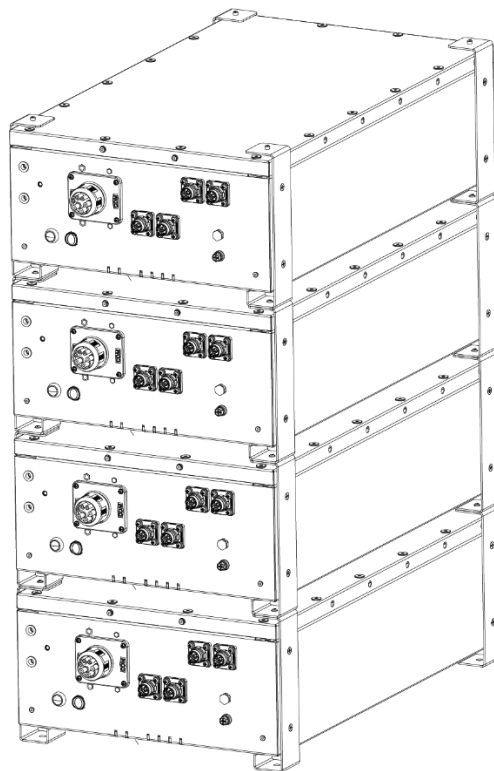

# 5 Cable Connection

## 5.1 Checking Cables

AWG	Maximum Current	Recommended Current
4 AWG	125 A	100 A

## 5.2 Connecting the Grounding Cable

Grounding cables should be 6 AWG or higher yellow-green cables. After connection, the resistance from battery grounding point to Ground connection point of room or installed place should be less than 0.1 Ω.

### Procedure

1. Connect a grounding cable to the grounding point of the modules.

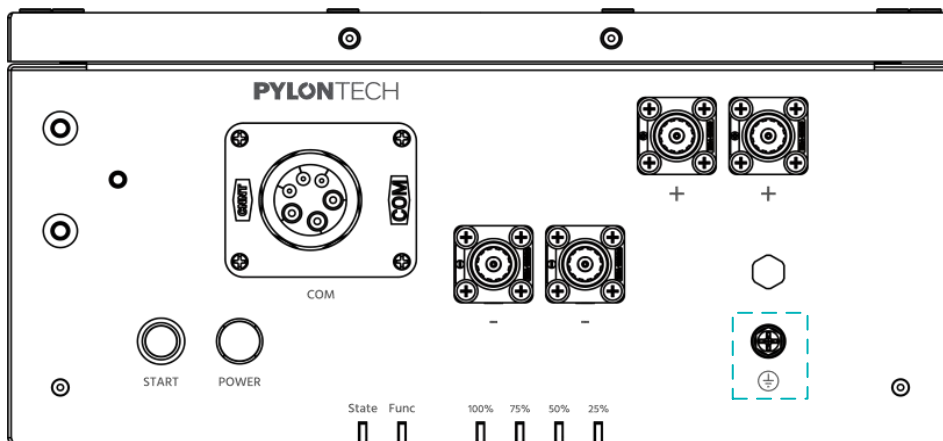

2. Grounding cables are required for inter-module connection when multiple modules are in use.

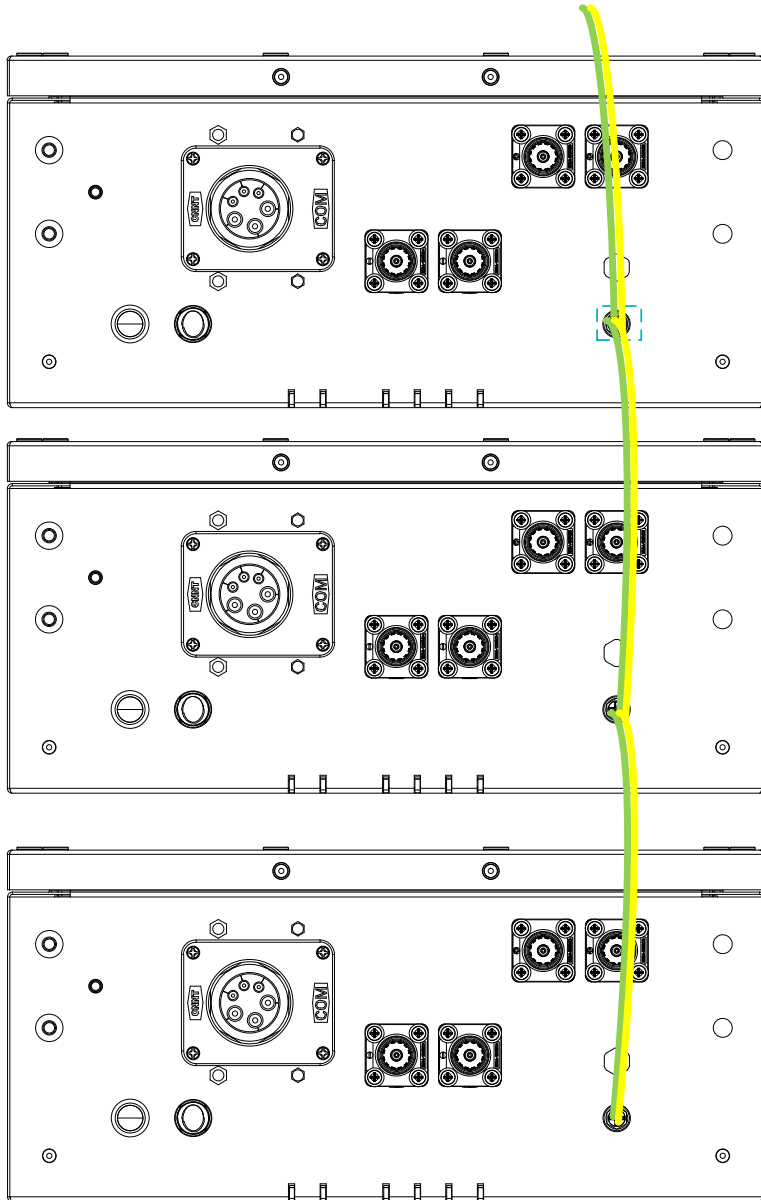

### 5.3 Single-string Cable Connection

#### Procedure

- 1. Connect the power cables and communication cables between batteries.
- 2. Connect the power cable and communication cable to the inverter.

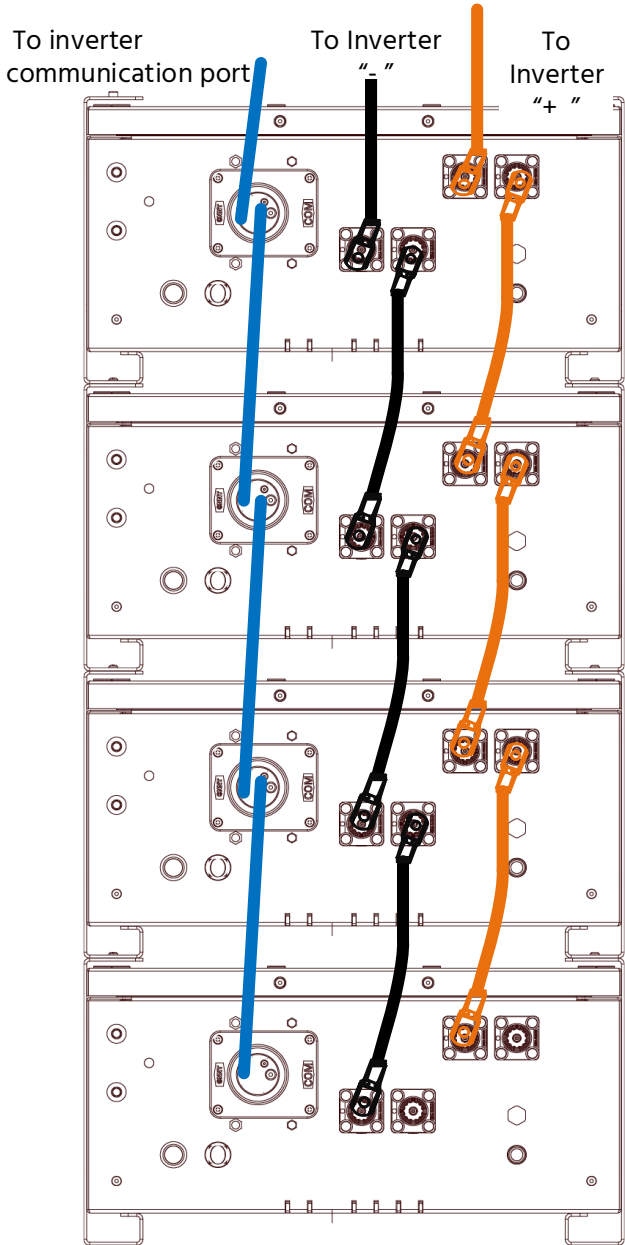

## Communication cable connection

The communication for master/slave battery connection shall use an 8 pin RJ45 cable, connecting from the first battery Link 1 to the second battery Link 0, then from the second battery Link 1 to third battery link 0(if has), all the way to the last battery Link 0.

The battery with Link 0 EMPTY is defined as the Master battery. Select either CAN or RS485 on the master battery for further connection with the inverter or upper controller.

The CAN/RS485 Port of the slave battery is ineffective in this case.

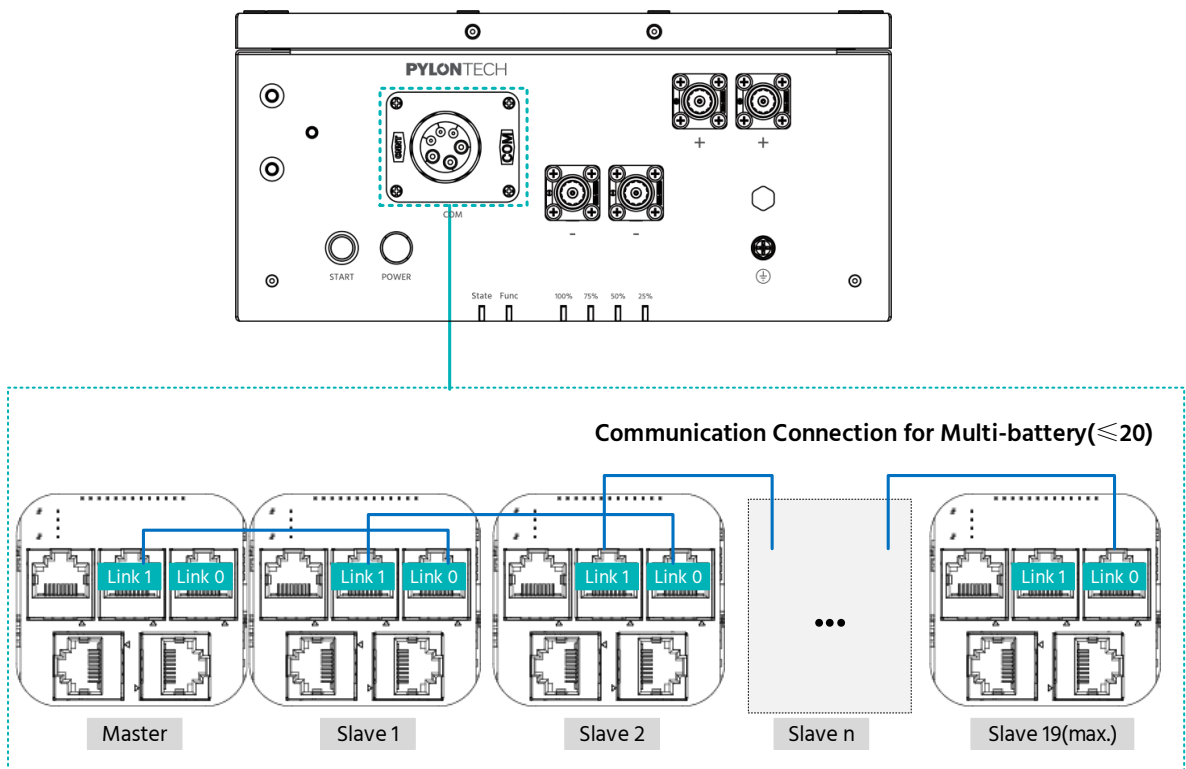

## 5.4 Multi-string Cable Connection

### Power cable connection

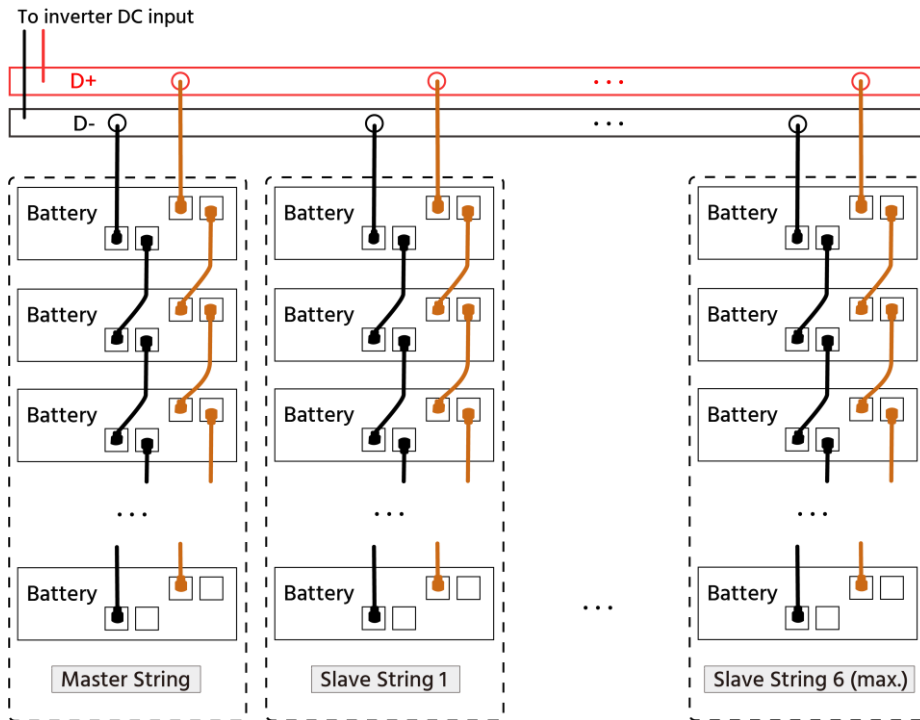

### Communication cable connection

**NOTE:** For parallel application of multiple batteries, LV-HUB-V2-Pro product is required.

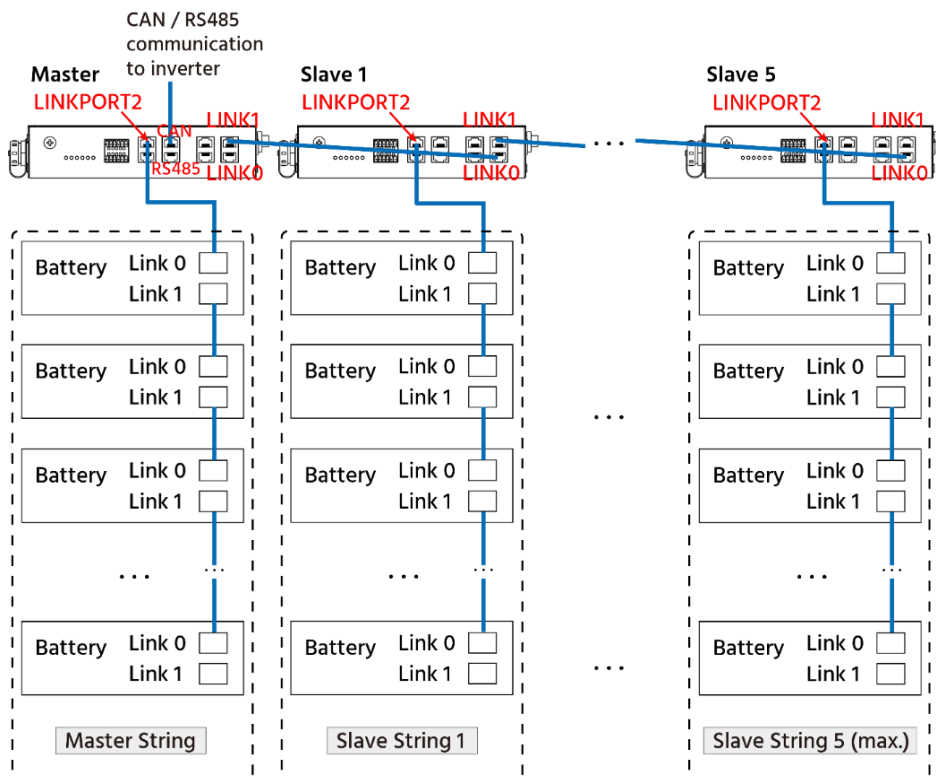

**NOTE:** After installation, DO NOT forget to register online to activate warranty:

[www.pylontech.com.cn/service/support](http://www.pylontech.com.cn/service/support).

## 5.5 Suitable Disconnection Device

It is recommended to have a disconnection device for protection between battery system and inverter:

1. The rated voltage should be  $\geq 60\text{VDC}$ . **DO NOT** use an AC breaker.
2. The rated current should match with system design:

The following factors shall be considered:

- The maximum DC current on inverter side.
  - The number of power cable: for instance, if there is only one pair of 4 AWG cable, the rated current of breaker shall be  $\leq 125\text{ A}$ .
3. If using a breaker, it shall be type C (recommended) or type D.

The Icu required: the maximum short circuit current for calculation of each module is 1000 A.

For instance:

Battery amount	Icu of breaker
1~4 modules	Must $\geq 4\text{ kA}$
5~8 modules	Must $\geq 8\text{ kA}$

## 6 Commissioning

### 6.1 System Turning On

Double-check all power and communication cables between batteries, and between battery and inverter. Once confirmed connected correctly, close the circuit breaker between the battery and the inverter (if any).

#### Procedure

1. Power on all the battery modules.

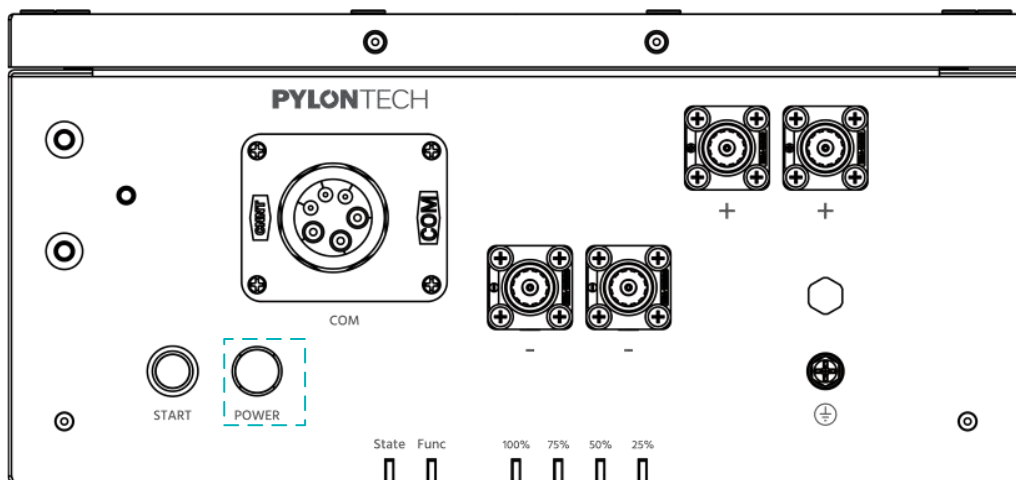

The one with **empty Link Port 0** is the **master battery**, others are slaves (1 master battery configuring maximum 19 slave batteries).

2. Press the **red start button** of **master battery** to turn on. After the master battery LED turns on, the LEDs on all the slave batteries will be on at the same time.

#### **NOTE:**

- After the battery module is powered on, the pre-charging circuit will continue to work for 3 seconds. Once the precharge is complete, the battery is ready for high power output.

**NOTE:** Restart the battery 2 to 3 times if pre-charging fails.

- When connecting modules with different SOC/voltage in parallel during expansion or replacement, it is recommended to maintain the system in IDLE for  $\geq 15$  minutes or till the SOC LEDs become similar ( $\leq 1$  dot difference) before normal operation.

## 6.2 System Turning Off

### Procedure

1. Turn external power source off.
2. Press the Start button of the master battery for 5 seconds, then release it, and all batteries will be turned off.

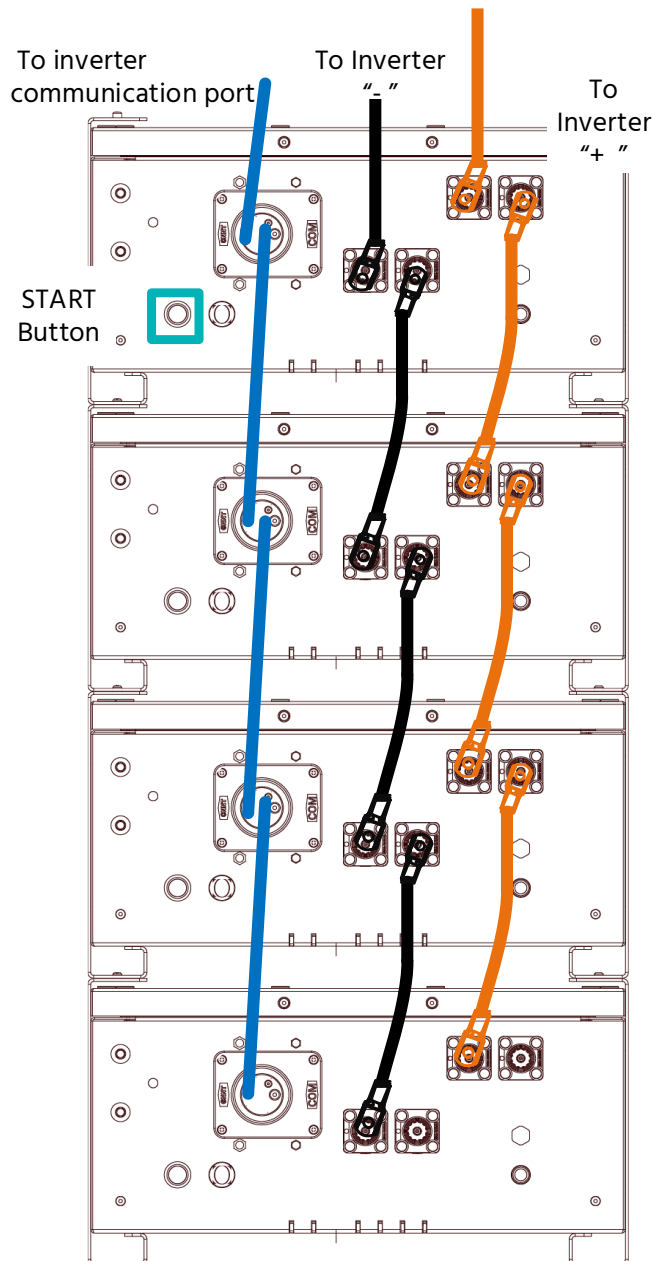

3. Turn Power Button to OFF on master battery and all slave batteries.
4. Disconnect the circuit breaker between the battery and the inverter (if any).

## 7 Troubleshooting

Item	Condition	Reason	Troubleshooting Methods
Communication Related Problems	Unable to communicate with inverter on compatible list.	Pin definitions	Check whether the CAN or 485 communication connection and PIN definition of the battery are correctly connected to the corresponding PIN definition of the inverter.
		RS485: baud rate	Please confirm if the 485 communication baud rate set by the master battery is correct, refer to the instructions of Start button and LED Status Indicators in <i>Section 2.3 Battery Interface</i> .
		Inverter Battery Setting Issue	Check whether the battery model selection is required in the inverter settings; the battery type must be selected as lithium battery or Pylontech battery.
Function Related Problems	Close the Power On switch, press and hold the Start button; the battery fails to start, however.	Capacity too low, or module over discharged.	Depending on the different battery terminal voltages, take the following 2 methods:  If the battery terminal voltage is $\leq 45$ VDC, use $\leq 0.05$ C to slowly charge the module to avoid affecting SOH;  If battery terminal voltage is $> 45$ VDC, use $\leq 0.5$ C to charge.  If the battery cannot start, turn off and repair the battery.
		BMS Damage	Use a multimeter to measure the battery module voltage. If the voltage is $> 45$ V but the battery fails to power on, the BMS may be

			damaged. Please contact your local distributor for repair.
		Battery Damage	If the module voltage is $< 35V$ , the battery is severely undercharged and poses a safety risk. It must be scrapped as soon as possible.
The battery can be turned on, but red light is on, and the battery cannot charge or discharge. If the red light is on, it means that system is abnormal		Normal operating temperature exceeding range	If the temperature is above $60^{\circ}C$ or under $-10^{\circ}C$ , the battery will not work. Move battery normal operating temperature to the between $0^{\circ}C$ and $50^{\circ}C$ .
		Charge-discharge current exceeding the operating range	The allowable charge-discharge rate of the battery varies under different temperatures and SOC conditions. The battery will activate protection when the current exceeds the recommended value. Please ensure that the inverter maintains continuous communication with the battery and confirm that the load does not exceed the battery's output capacity.
		Operating voltage exceeding the range	When the charging voltage is higher than $57.6 V$ , the battery protection will be activated. Please check if the voltage is too high. If yes, adjust the settings on the power supply side and discharge the module.
		Battery Lockout	If battery faults cannot be resolved after multiple attempts of standing idle and restarting, it may be due to the activation of lockout protection. In such cases, please contact your local

			distributor for fault diagnosis and maintenance
	Unable to charge and discharge with red LED on.	BMS failure.	Power off the module and contact your local distributor.
Heating Related Problems	The inability of batteries to heat up at low temperatures	Confirm whether the battery is a heating model.	Only FB-L-5.12-Pro supports heating. Please ensure the battery model is correct.
		Verify if the battery heating function is enabled.	The heating function can be turned on or off via the battery's function buttons. It is enabled by default at the factory. Please check if it was accidentally turned off during use.
		Battery temperature not reaching the heating threshold	Either the cell temperature is too low, exceeding the operable range; or the battery temperature is too high, not reaching the set heating activation temperature.
		Not within the heating time period	The heating time period can be set via the APP. If a heating time period is set, the battery will only heat within the specified time.
		Insufficient energy	The battery cannot activate self-heating due to low power. The PCS has no extra energy to charge and heat the battery.
	Heating function fault	Damage to heating film-related components	When a heating function fault is reported, this fault cannot be repaired. However, it can be temporarily masked via the function button. After masking, the battery can be used normally

			as a non-heating model. If you wish to retain the heating function, please contact your local distributor.
	The heating temperature fails to rise.	Insufficient heating current	When the PCS is charging and heating the battery, if the output power of the PCS is too low, it will fail to meet the heating power requirements.
		Heating film detachment	If the heating film has detached from the battery and the issue is confirmed not caused by insufficient heating current, please contact after-sales service personnel for replacement and repair.
When a data acquisition stick is optionally equipped and the acquisition stick is connected to the network, the battery will report specific faults to the APP. The faults reported by the battery can be viewed intuitively on the APP. Contacting after-sales service personnel based on the specific fault causes will result in higher efficiency.			

**Excluding the points above, if the faulty still cannot be located, turn off battery and contact your local distributor.**

## 8 Emergency Situations

**⚠ CAUTION**

**Caution:** Damaged batteries may leak electrolyte or produce flammable gas.

Problem	Description	Action	
Leaking Batteries	If the battery pack leaks electrolyte, avoid contacting with the leaking liquid or gas. If anyone is exposed to the leaked substance, immediately perform the actions.	Inhalation.	Evacuate the contaminated area and seek medical attention.
		Contact with eyes.	Rinse eyes with flowing water for 15 minutes and seek medical attention as soon as possible.
		Contact with skin.	Wash the affected area thoroughly with soap and water, and seek medical attention as soon as possible.
		Ingestion.	Induce vomiting and seek medical attention.
Fire	The battery cell is catching fire.	<ol style="list-style-type: none"> <li>1. Firstly, cut off the external power supply.</li> <li>2. Then use vast of water for suppression.</li> <li>3. After extinguishing the fire, soak the battery in water and contact Pylontech or an authorized dealer.</li> </ol>	
	The cabling or other component (not battery cell) is catching fire.	<ol style="list-style-type: none"> <li>1. Firstly, cut off the external power source.</li> <li>2. Then use dry powder fire or carbon dioxide extinguisher for suppression.</li> </ol>	
Wet Batteries	The battery module is wet or submerged in water.	<ol style="list-style-type: none"> <li>1. Cut off all power switch on inverter side.</li> <li>2. DO NOT let people access it, and contact Pylontech or an authorized dealer for technical support.</li> </ol>	
Damaged Batteries	Damaged batteries are dangerous and must be handled with the utmost care. They are not fit for use and may pose a danger to people or property.	If the battery pack seems to be damaged, pack it in its original container, and then return it to Pylontech or an authorized dealer.	

## 9 Remarks

### 9.1 Recycle and Disposal.

If a battery (normal condition or damaged) needs disposal or needs recycling, follow the local recycling regulation (i.e. Regulation (EC) N° 1013/2006 among European Union) to process, and use the best available techniques to achieve a relevant recycling efficiency.



### 9.2 Storage, Maintenance and Expansion

1. If the battery needs to be stored for a long period, please refer to the following storage conditions and requirements:

Storage Temperature Range	Maximum Storage Duration	Battery Power Before Storage
-20~45°C	1 month	>30%
0-35°C	6 months	>50%

The maximum storage duration of the battery is 6 months. If this period is exceeded, the battery must be activated through charge-discharge cycles. It is recommended to perform 2~3 charge-discharge cycles on the battery before storing it again.

2. It is suggested to check the connection of power connector, grounding point, power cables and screws every year after installation. Make sure that there is no loose, no broken, no corrosion at connection points. Check the installation environment such as dust, water, insect etc. Make sure that it is suitable for IP65 battery system.
3. A new battery module can be added onto an existing system at any time. Make sure that the new battery is acting as the master. The new module, due to a higher SOH may have a difference on SOC with existing system, but it will not affect the parallel connection system performance.



**Pylon Technologies Co., Ltd.**

No.300, Miaoqiao Road, Kangqiao Town

Pudong New Area, Shanghai 201315, China

**T** +86-21-51317699

**E** [service@pylontech.com.cn](mailto:service@pylontech.com.cn)

**W** [www.pylontech.com.cn](http://www.pylontech.com.cn)